

BLOCK DIAGRAM

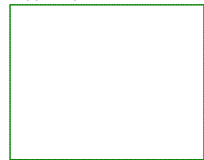

A_CFG8

VG-230

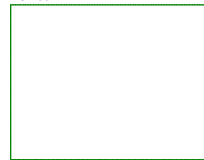

B_CFG8

SYSTEM MEMORY

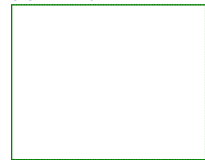

C_CFG8

MODEM/SERIAL I/F

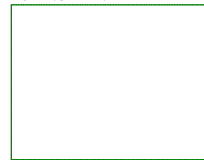

D_CFG8

I/O CONNECTORS

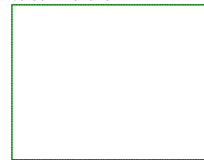

E_CFG8

PCMCIA BUFFERS

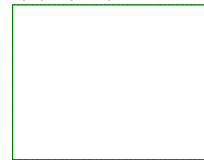

F_CFG8

PCMCIA CONNECTORS

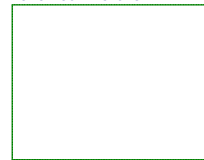

G_CFG8

THESE SCHEMATICS ARE PROVIDED AS A DESIGN GUIDE ONLY.
VADEM ASSUMES NO RESPONSIBILITY FOR FINAL SYSTEM DESIGN.

VADEM		
Title VG-230 SAMPLE SCHEMATICS - CONFIG. 8		
Size B	Document Number	Rev 3
Date: Wednesday, March 17, 2004		Sheet 1 of 8

VG-230 - CONFIGURATION 8

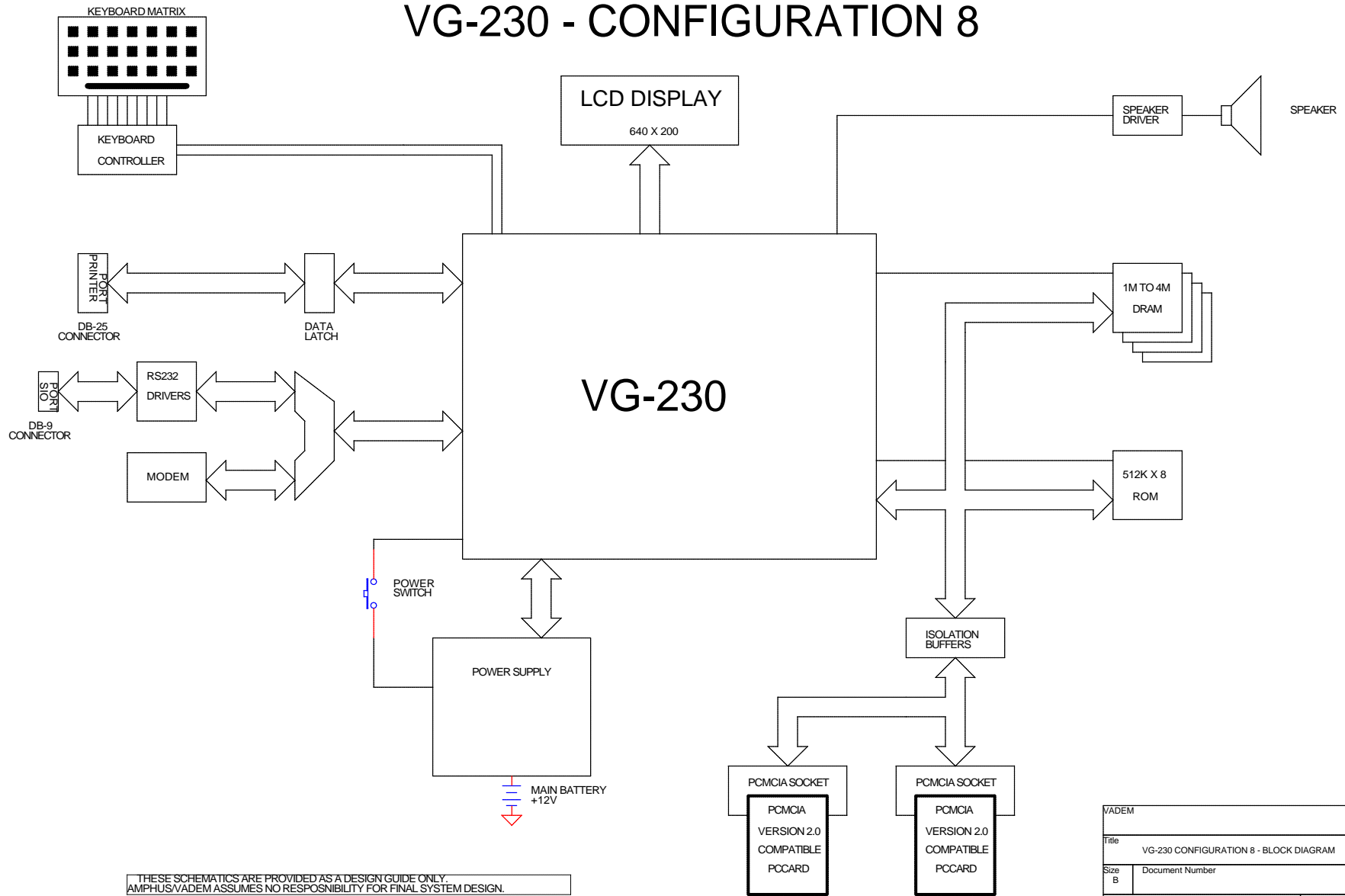

THESE SCHEMATICS ARE PROVIDED AS A DESIGN GUIDE ONLY.
 AMPHUS/VADEM ASSUMES NO RESPONSIBILITY FOR FINAL SYSTEM DESIGN.

VADEM		
Title VG-230 CONFIGURATION 8 - BLOCK DIAGRAM		
Size B	Document Number	Rev 4
Date: Wednesday, March 31, 2004	Sheet 2 of 8	

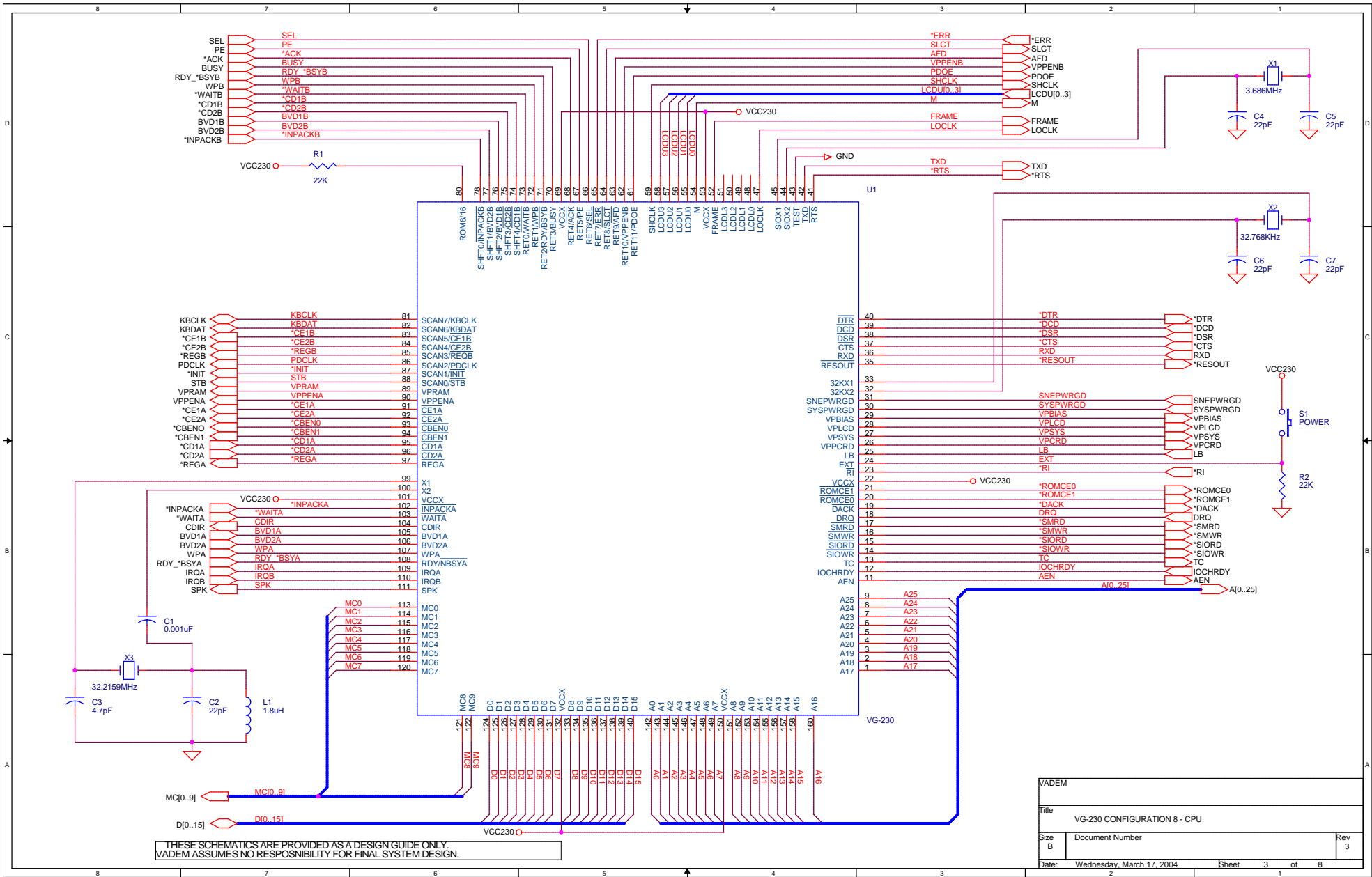

THESE SCHEMATICS ARE PROVIDED AS A DESIGN GUIDE ONLY.
VADEM ASSUMES NO RESPONSIBILITY FOR FINAL SYSTEM DESIGN.

VADEM		
Title VG-230 CONFIGURATION 8 - CPU		
Size B	Document Number	Rev 3
Date: Wednesday, March 17, 2004	Sheet 3	of 8

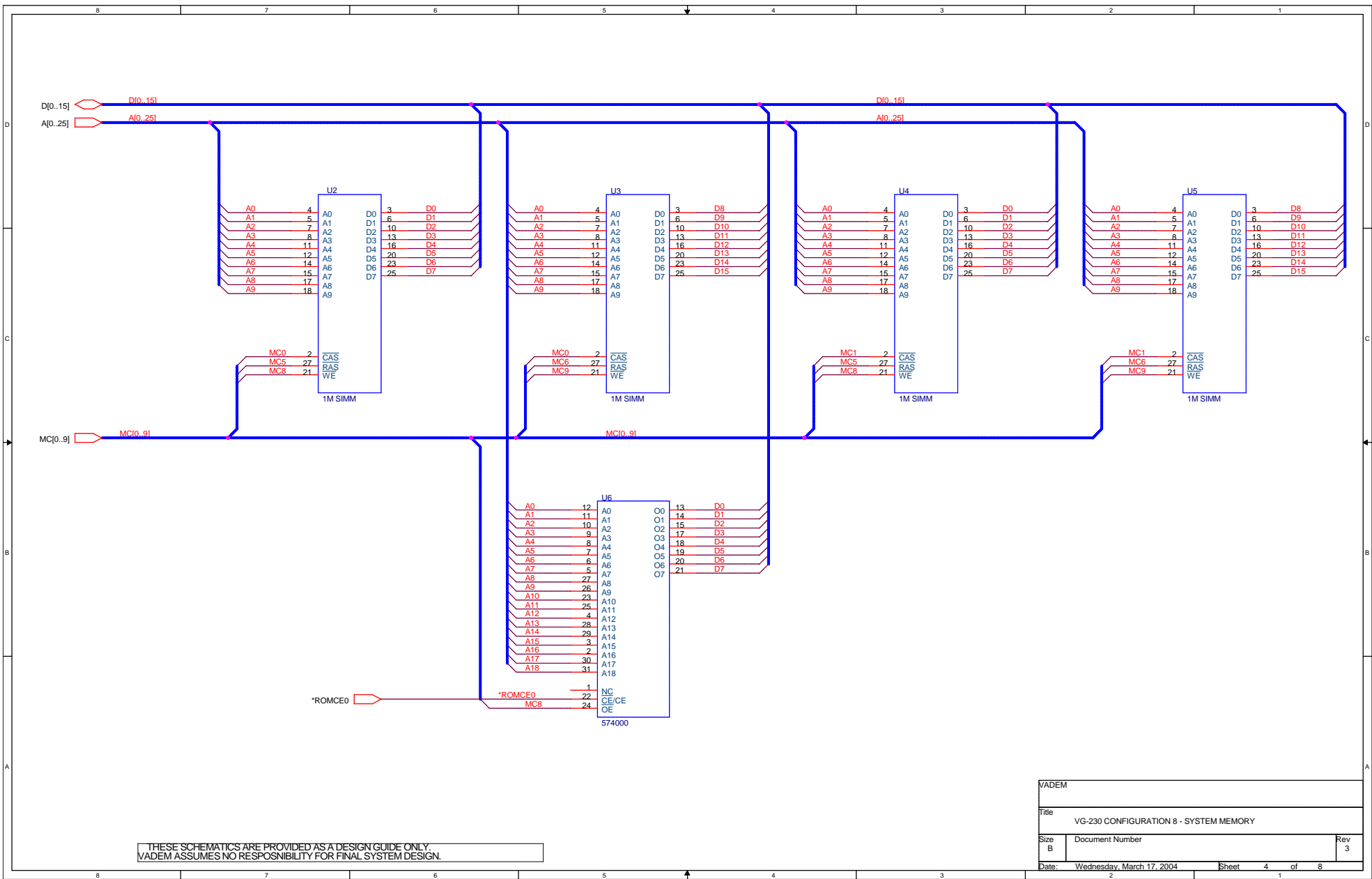

THESE SCHEMATICS ARE PROVIDED AS A DESIGN GUIDE ONLY.
VADEM ASSUMES NO RESPONSIBILITY FOR FINAL SYSTEM DESIGN.

VADEM		
Title VG-230 CONFIGURATION 8 - SYSTEM MEMORY		
Size B	Document Number	Rev 3
Date: Wednesday, March 17, 2004	Sheet 4	of 8

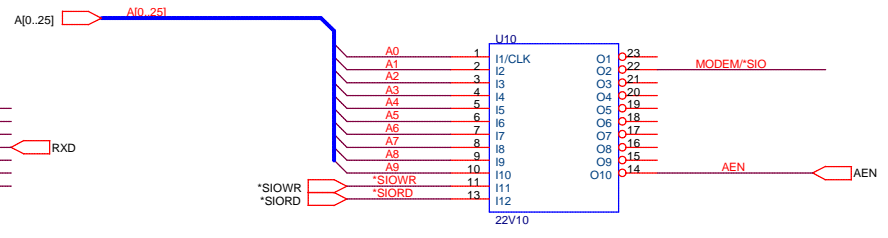
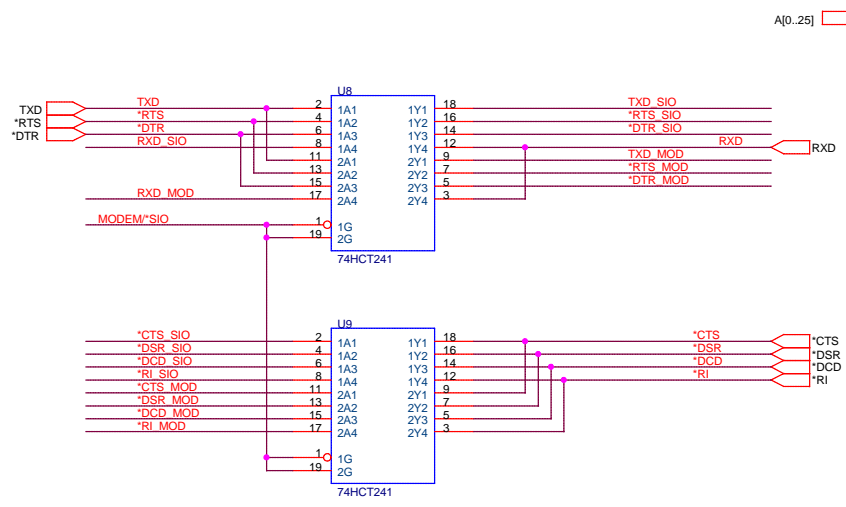
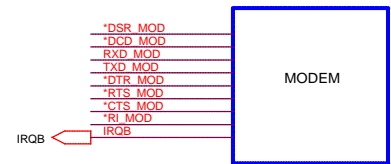
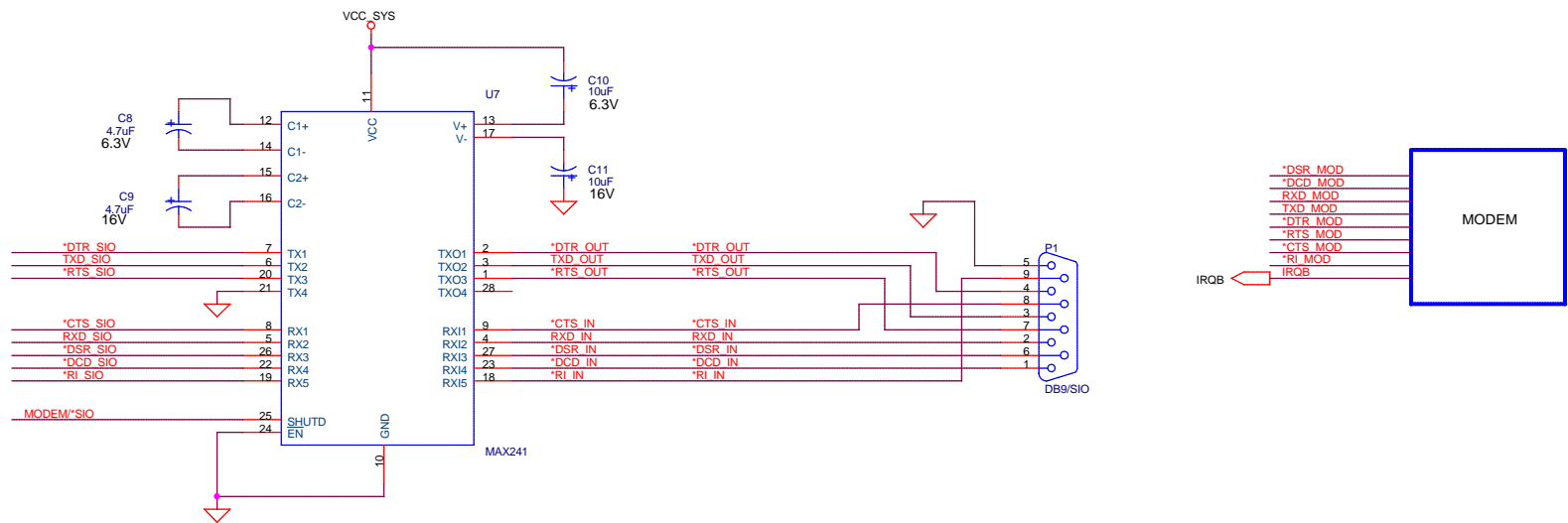

THESE SCHEMATICS ARE PROVIDED AS A DESIGN GUIDE ONLY.
VADEM ASSUMES NO RESPONSIBILITY FOR FINAL SYSTEM DESIGN.

VADEM		
Title VG-230 CONFIGURATION 8 -MODEM/SERIAL I/F		
Size B	Document Number	Rev 3
Date: Wednesday, March 17, 2004	Sheet 5	of 8

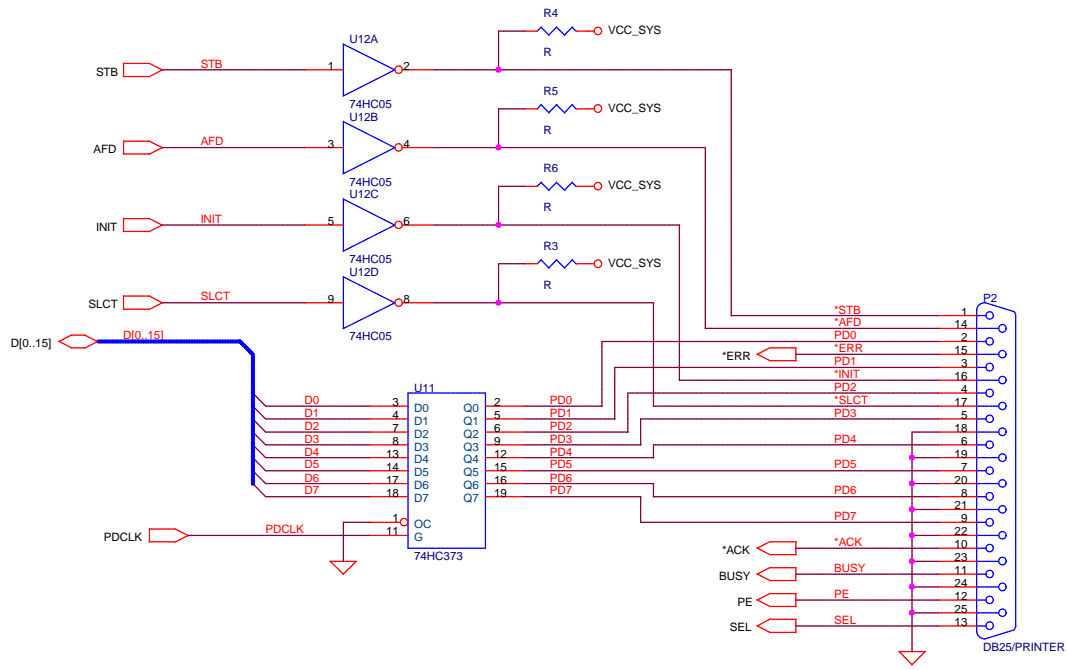
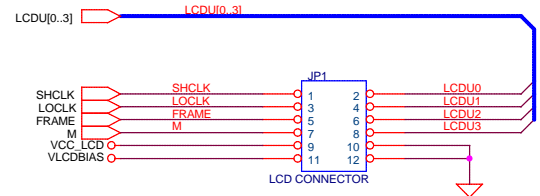
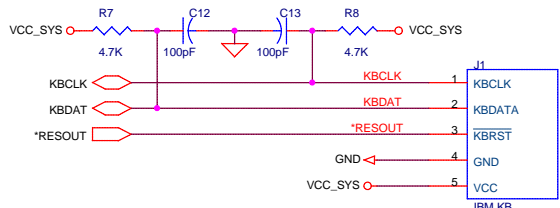

THESE SCHEMATICS ARE PROVIDED AS A DESIGN GUIDE ONLY.
VADEM ASSUMES NO RESPONSIBILITY FOR FINAL SYSTEM DESIGN.

VADEM		
Title VG-230 CONFIGURATION 8 - I/O CONNECTORS		
Size B	Document Number	Rev 3
Date: Wednesday, March 17, 2004	Sheet 6 of 8	

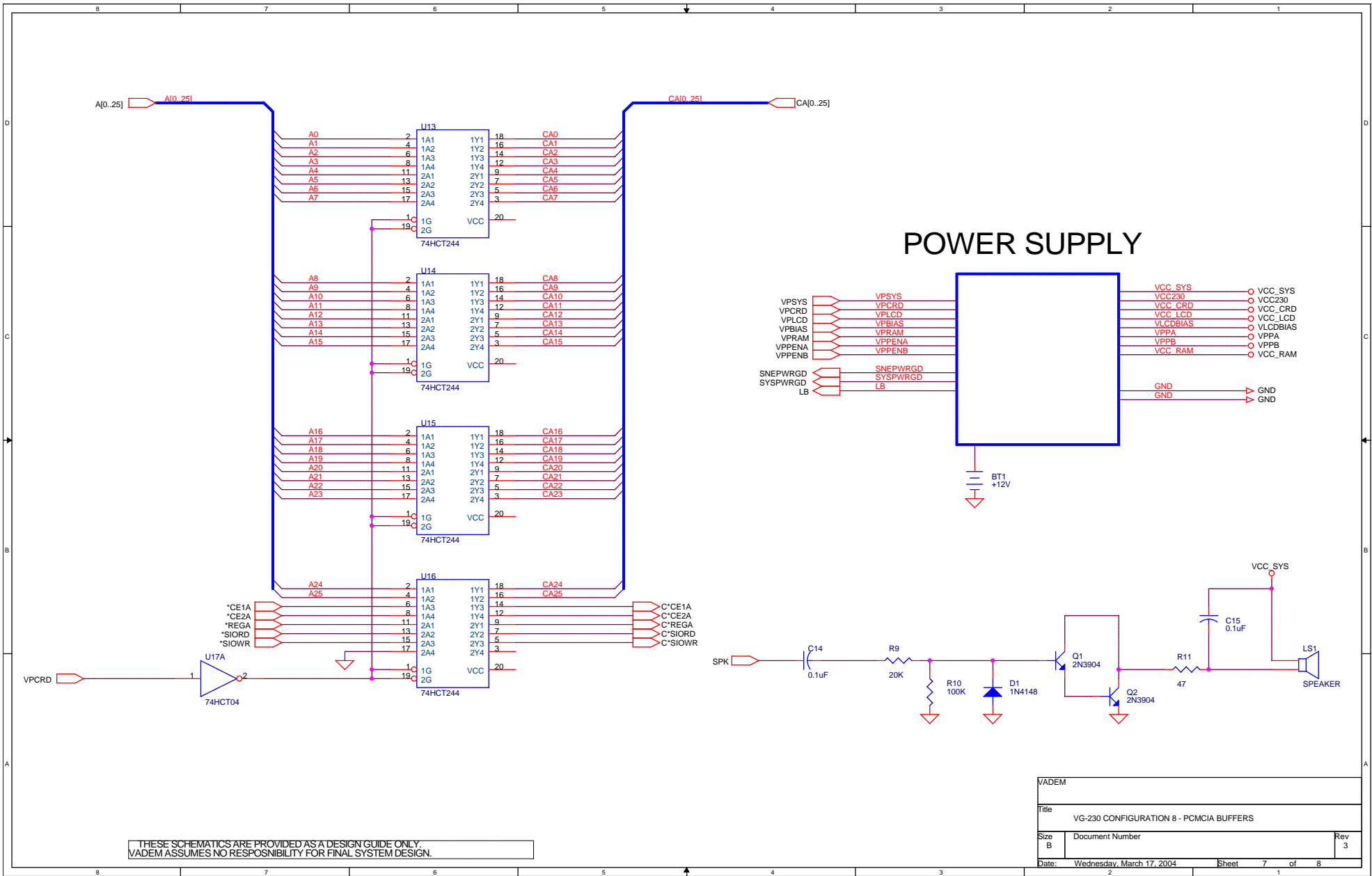

THESE SCHEMATICS ARE PROVIDED AS A DESIGN GUIDE ONLY.
VADEM ASSUMES NO RESPONSIBILITY FOR FINAL SYSTEM DESIGN.

VADEM		
Title: VG-230 CONFIGURATION 8 - PCMCIA BUFFERS		
Size B	Document Number	Rev 3
Date: Wednesday, March 17, 2004		Sheet 7 of 8

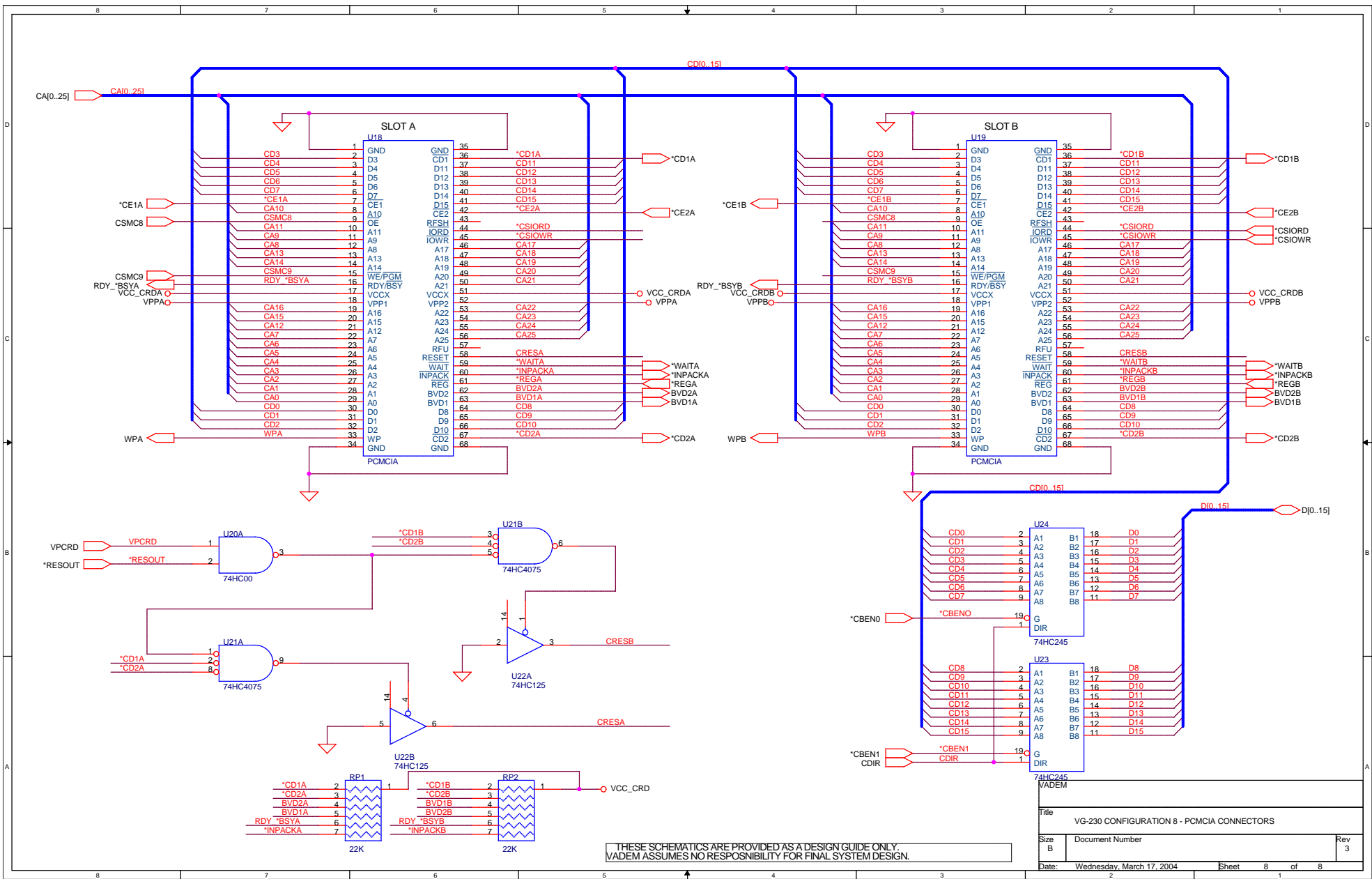

THESE SCHEMATICS ARE PROVIDED AS A DESIGN GUIDE ONLY. VADEM ASSUMES NO RESPONSIBILITY FOR FINAL SYSTEM DESIGN.

Title		
VG-230 CONFIGURATION 8 - PCMCIA CONNECTORS		
Size	Document Number	Rev
B		3
Date: Wednesday, March 17, 2004		Sheet 8 of 8