

BLOCK DIAGRAM

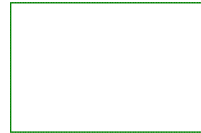

A_CFG5

VG-230



B_CFG5

SYSTEM MEMORY

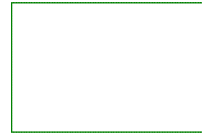

C_CFG5

I/O CONNECTORS

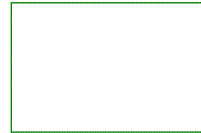

D_CFG5

PCMCIA CONNECTORS



E_CFG5

PWR SUP / BUFFERS

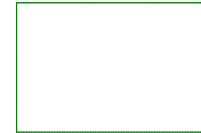

F_CFG5

NTSC VIDEO PORT



G_CFG5

THESE SCHEMATICS ARE PROVIDED AS A DESIGN GUIDE ONLY.
VADEM ASSUMES NO RESPONSIBILITY FOR FINAL SYSTEM DESIGN.

VADEM		
Title VG-230 SAMPLE SCHEMATICS - CONFIG. 5		
Size B	Document Number	Rev 4
Date: Wednesday, March 17, 2004		Sheet 1 of 8

VG-230 - CONFIGURATION 5

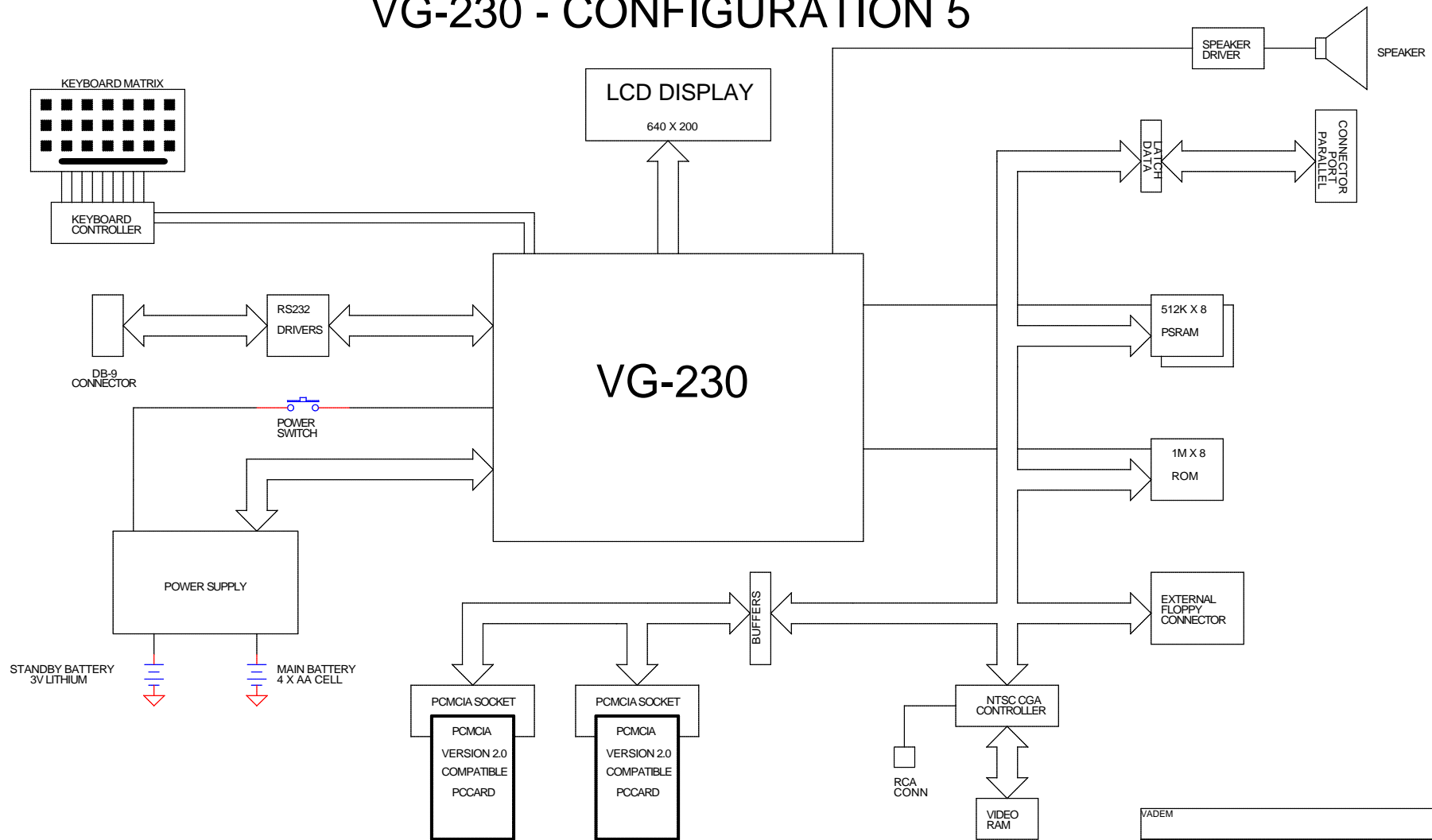

THESE SCHEMATICS ARE PROVIDED AS A DESIGN GUIDE ONLY.
 AMPHUS/VADEM ASSUMES NO RESPONSIBILITY FOR FINAL SYSTEM DESIGN.

VADEM		
Title VG-230 CONFIGURATION 5 - BLOCK DIAGRAM		
Size B	Document Number	Rev 4
Date: Wednesday, March 31, 2004	Sheet 2 of 8	

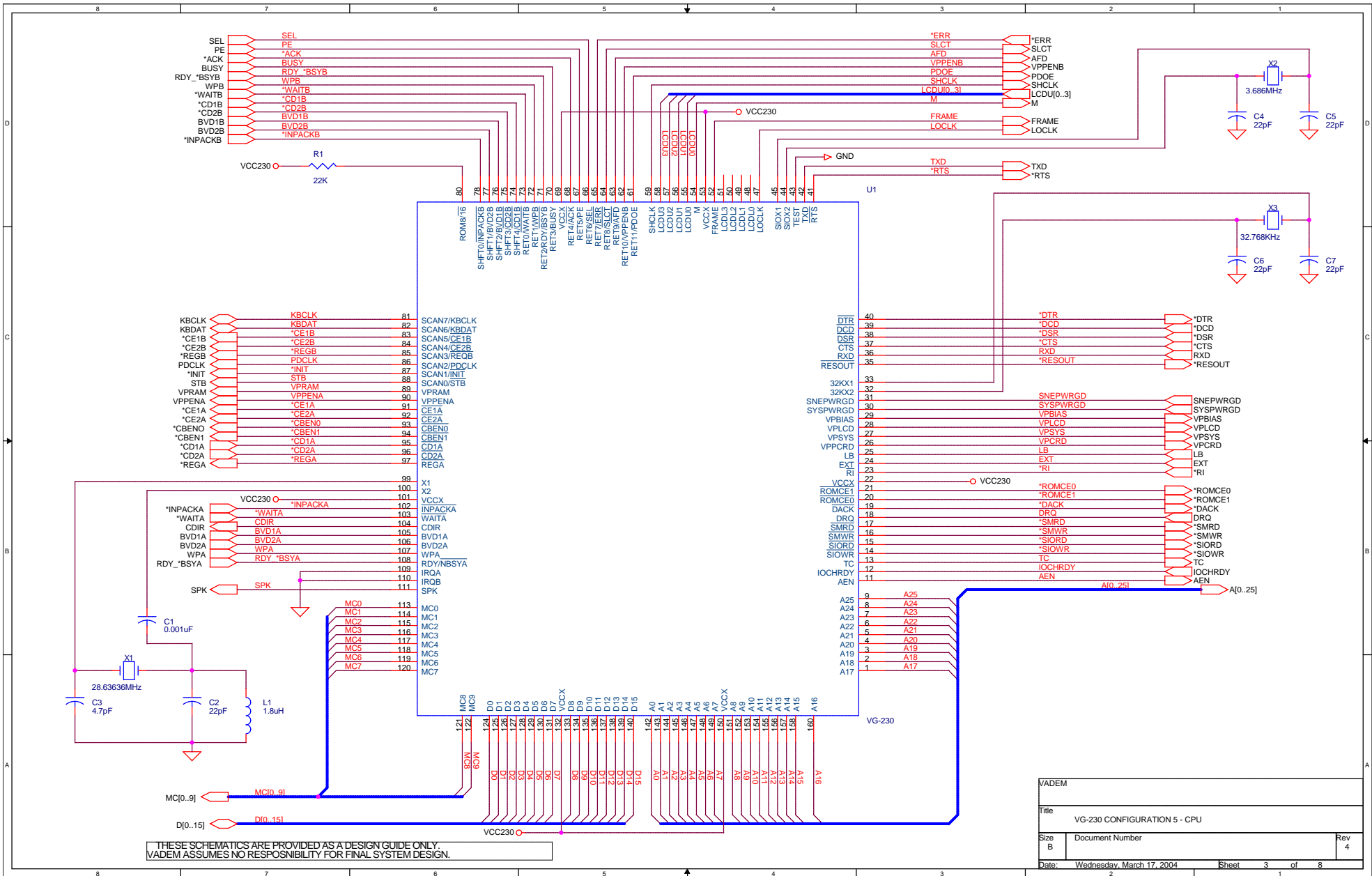

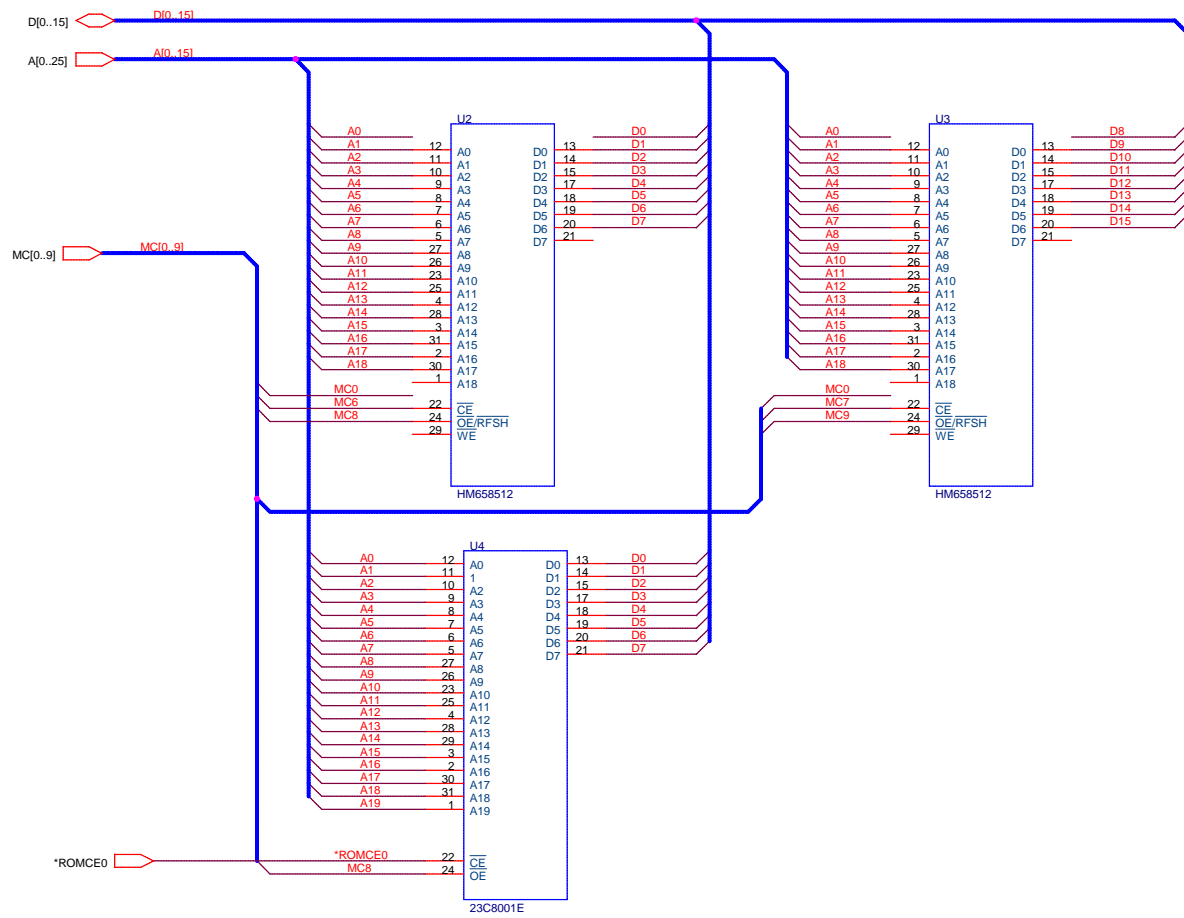

THESE SCHEMATICS ARE PROVIDED AS A DESIGN GUIDE ONLY.
VADEM ASSUMES NO RESPONSIBILITY FOR FINAL SYSTEM DESIGN.

VADEM		
Title VG-230 CONFIGURATION 5 - SYSTEM MEMORY		
Size B	Document Number	Rev 4
Date: Wednesday, March 17, 2004	Sheet 4 of 8	

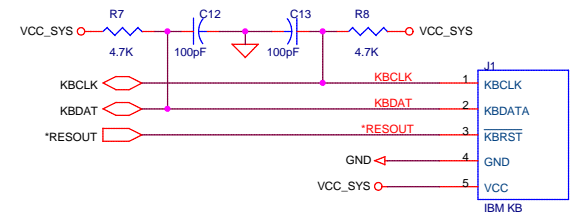
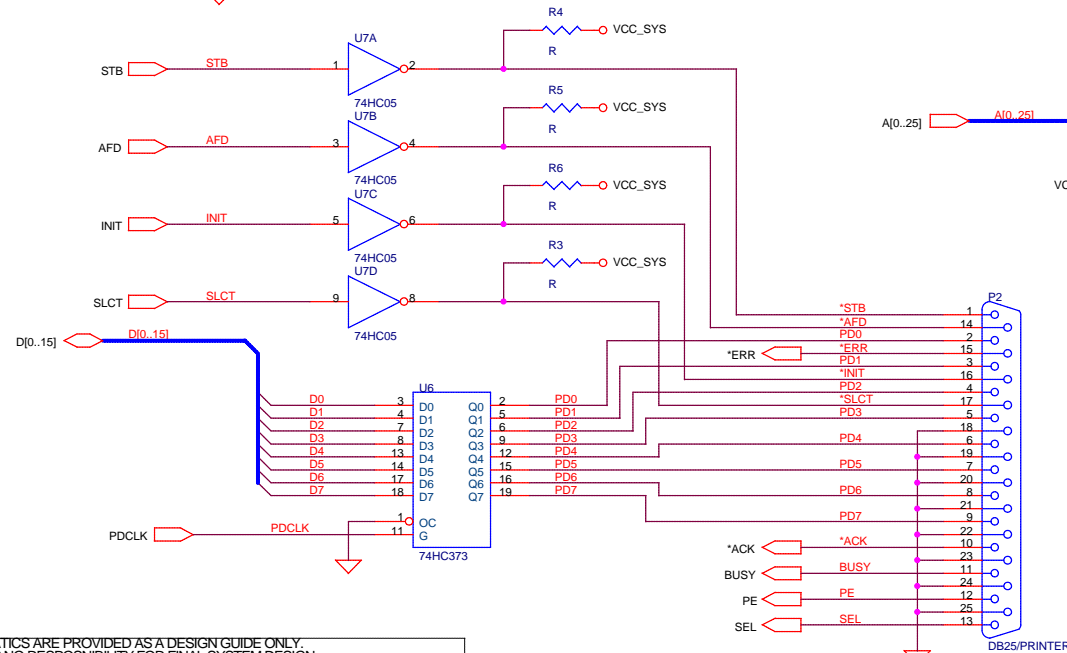
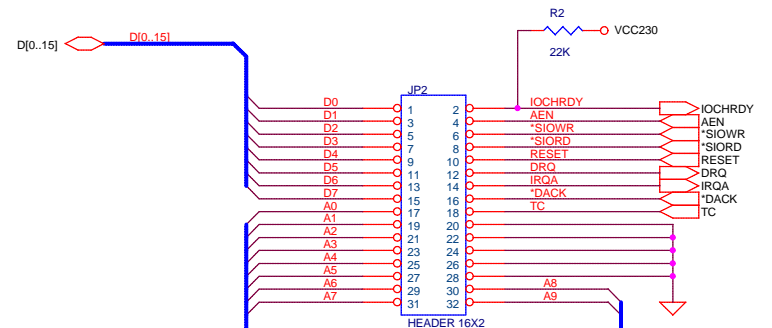
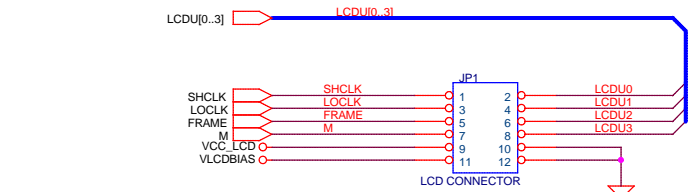
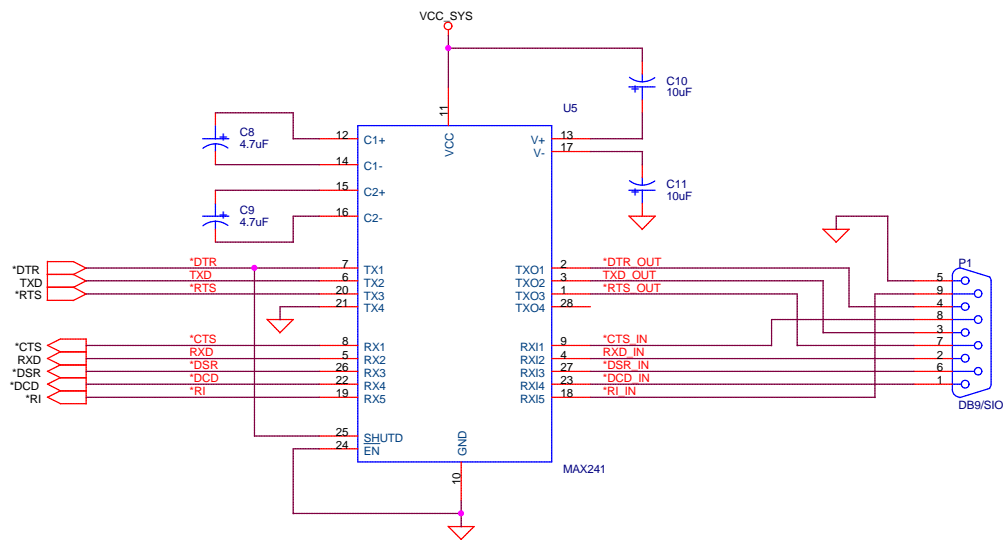

THESE SCHEMATICS ARE PROVIDED AS A DESIGN GUIDE ONLY. VADEM ASSUMES NO RESPONSIBILITY FOR FINAL SYSTEM DESIGN.

VADEM		
Title VG-230 CONFIGURATION 5 - I/O CONNECTORS		
Size B	Document Number	Rev 4
Date: Wednesday, March 17, 2004	Sheet 5	of 8

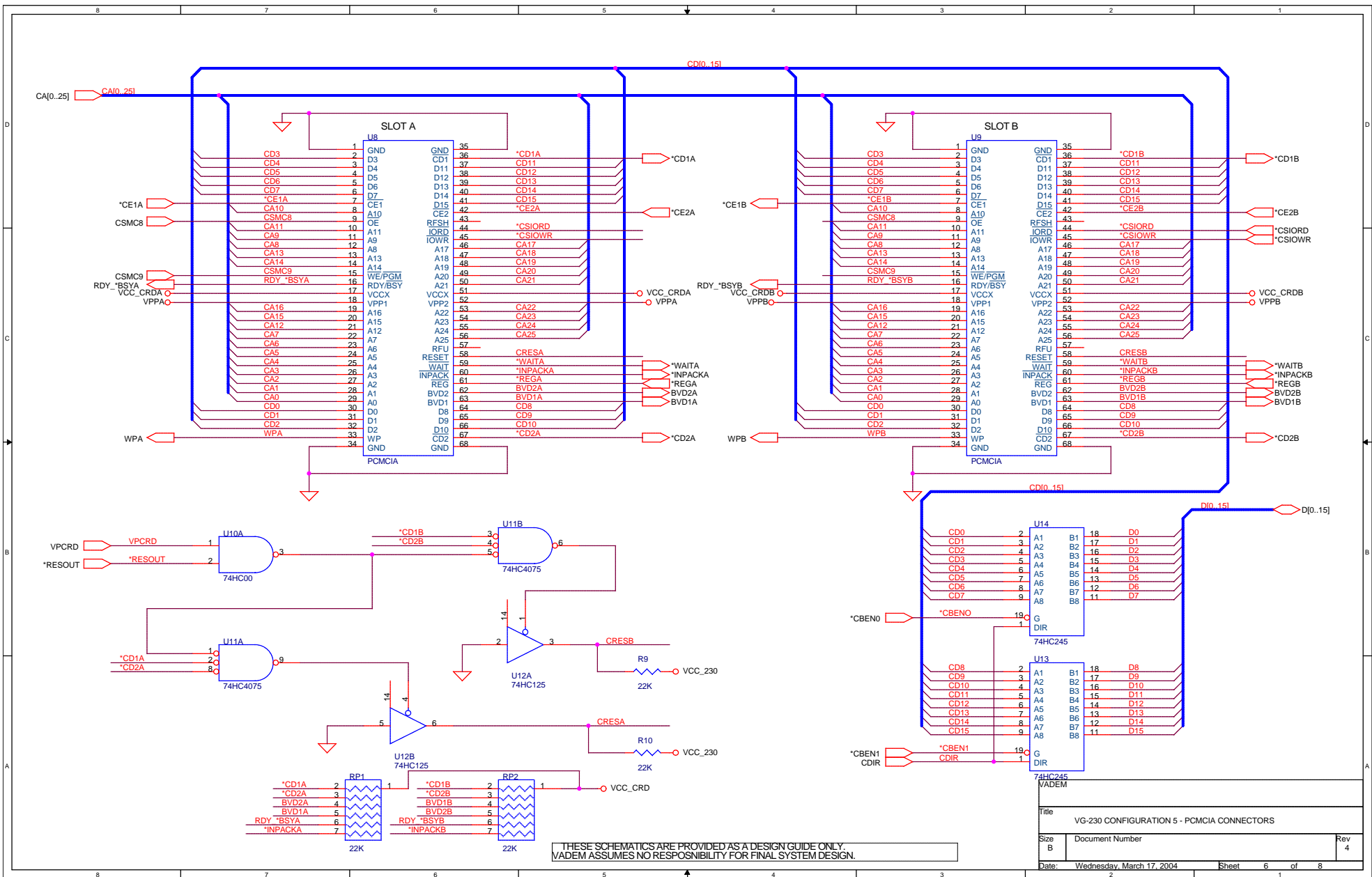

THESE SCHEMATICS ARE PROVIDED AS A DESIGN GUIDE ONLY.
VADEM ASSUMES NO RESPONSIBILITY FOR FINAL SYSTEM DESIGN.

Title		
VG-230 CONFIGURATION 5 - PCMCIA CONNECTORS		
Size	Document Number	Rev
B		4
Date:	Wednesday, March 17, 2004	Sheet 6 of 8

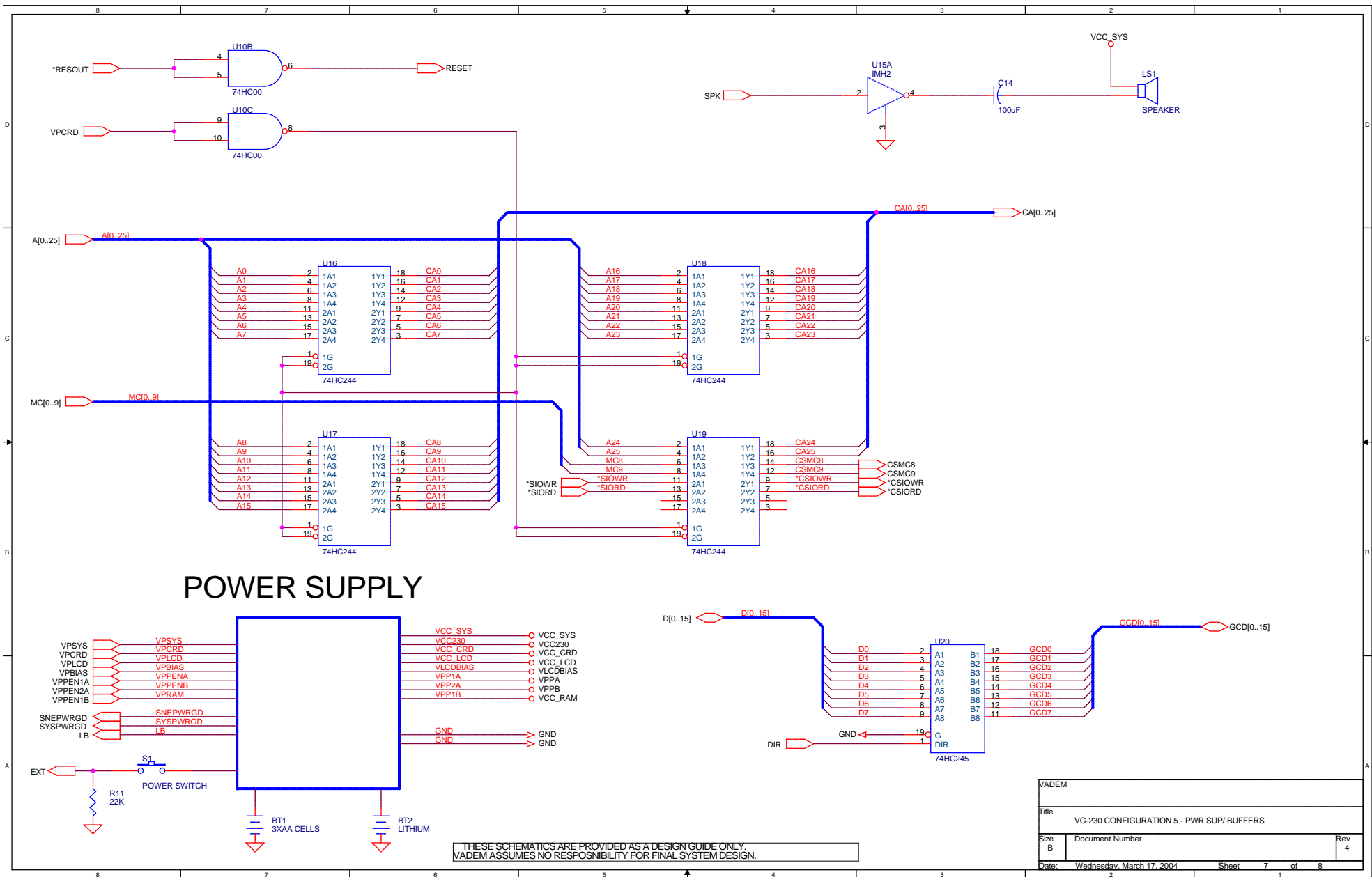

VADEM		
Title VG-230 CONFIGURATION 5 - PWR SUP/ BUFFERS		
Size B	Document Number	Rev 4
Date: Wednesday, March 17, 2004	Sheet 7 of 8	

